

## M1712 – M1712.5 Geareducer®

The Marley M Series Geareducer is designed and manufactured to directly replace Amarillo® cooling tower gearboxes for power and industrial applications. In form and function, this gear drive goes beyond the AGMA (American Gear Manufacturers Association) requirements to maximize air movement through the cooling tower and to minimize maintenance.

W Series Geareducers for very large fan loads are also available. Contact SPX Cooling Technologies for additional information.

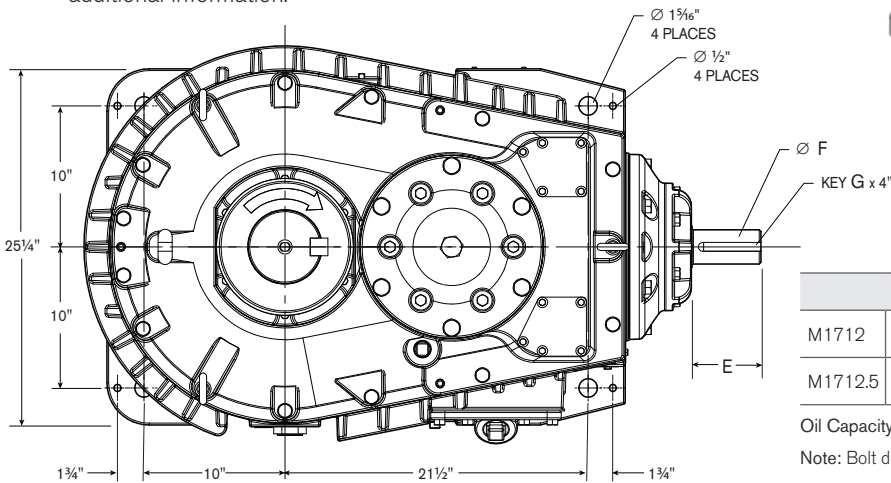
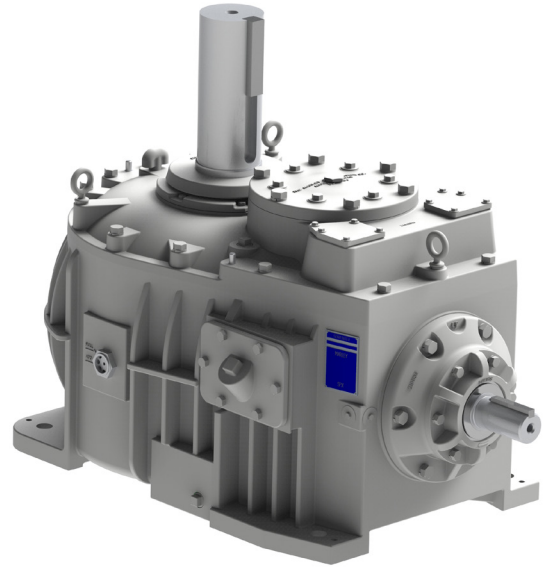

	A	B	C	D	E	F	G	H	weight
M1712	11"	25 1/2"	35 7/8"	33 3/4"	4 15/16"	2.4365" 2.4355"	5/8" x 5/8"	1 1/2"	2500 lb
M1712.5	12"	26 1/2"	36 7/8"	35 3/4"	5 13/16"	2.9365" 2.9355"	3/4" x 3/4"	2 1/2"	2650 lb

Oil Capacity: 17 USG

Note: Bolt down hardware based on specific support structure by others.

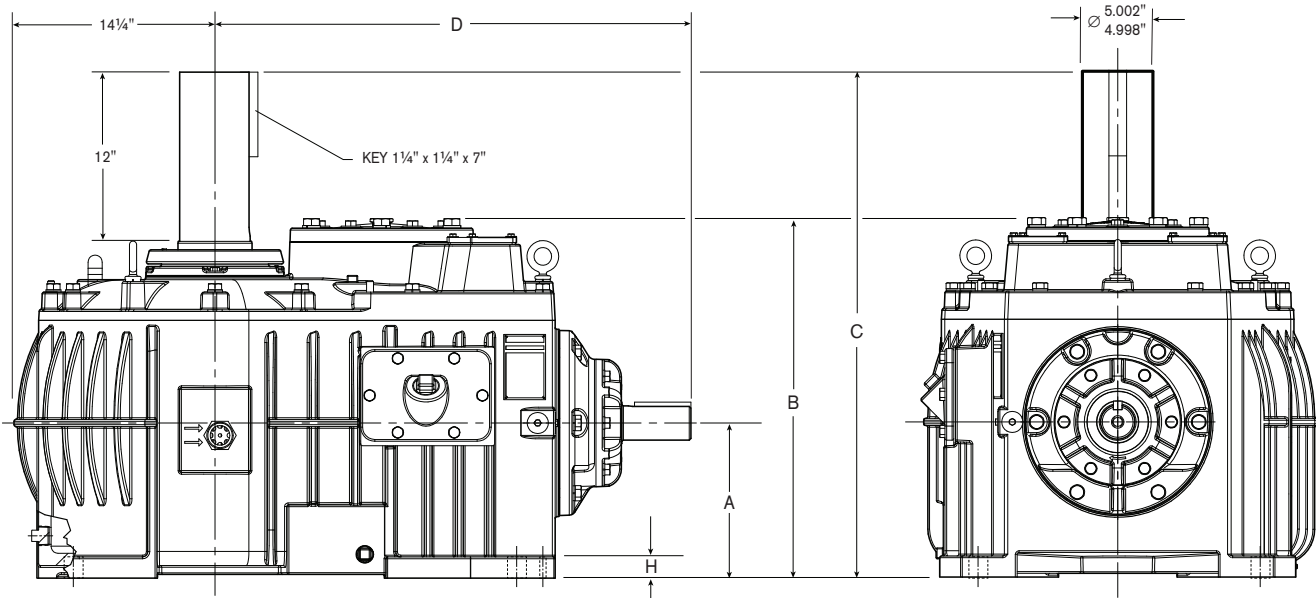

Reduction	Output RPM		Input hp Limitations per AGMA 2.0 SF	
	1775 RPM	1475 RPM	1775 RPM	1475 RPM
9.64	184	153	316	272
10.83	164	136	316	272
11.55	154	128	304	263
12.18	146	121	326	274
12.98	137	114	304	263
13.24	134	111	251	217
13.81	129	107	290	244
14.88	119	99	251	217
15.84	112	93	251	214
16.49	108	89	204	175
18.54	96	80	204	175
19.72	90	75	204	175

AGMA power limits can be higher than Amarillo unit being replaced resulting in a higher application service factor

## Specifications

Geareducer assemblies shall be double reduction right angle units utilizing helical and spiral bevel gear sets. Gear reducers shall meet or exceed the requirements of CTI STD-111 and AGMA Std. 6013-A06, and service factor at applied horsepower shall not be less than 2.0.

Cases shall be epoxy-coated, ASTM Class 20, gray cast iron. Housing design shall include external cooling fins for reduced operating oil temperatures without need for oil coolers or input shaft cooling fans. Heavy duty housings with wall thicknesses of no less than  $\frac{3}{8}$ " are utilized to provide sufficient strength and rigidity to maintain gear alignment and provide smooth, quiet operation under maximum operating loads.

Bearings shall be tapered roller type. L<sub>10A</sub> bearing life of all bearings must exceed 100,000 hours at the maximum rated speed and power. Interstage shaft shall have double row tapered roller bearings at top and bottom shaft positions.

Gears and bearings shall be splash-lubricated in a bath of oil which complies with the OEM's recommendations, and units shall be capable of operating in either forward or reverse with equal lubrication capability. Speed reduction units using external oil pumps shall not be permitted. All internal oil passage ports shall be at least  $\frac{3}{4}$ " diameter or have a larger cross sectional area.

The gear materials shall be AISI 8620 steel, with case-hardened teeth that have been surface ground to the final profile or lapped in matched sets. Gear tooth finish shall be AGMA class 9 or better. Both the spiral bevel pinion gear and helical pinion gear shall be integral with their shaft. Keyed or splined attachment of pinions to their shafts is not allowed.

The input shaft shall utilize a premium Inpro/Seal® bearing isolator type oil seal with a fixed stator sealing surface that wears against a hardened rotor to prevent shaft wear while providing long sealing life. Standard lip type seals that wear against the pinion shaft are not permitted.

The assembly design shall utilize metallic shims to achieve and maintain ideal gear setting and bearing adjustment throughout the life of the unit. Assemblies shall be run-in with torque and fan shaft thrust and adjusted at the factory. The interior surfaces shall be coated with a rust-proofing oil prior to shipment.

The Geareducer's primary function is to reduce the speed of the electric motor to optimize fan performance. M Series also provides primary support to the fan, anchors it against lateral movement, withstands shock loads at start-up and during speed changes, and minimizes power transmission losses and noise generation.

### SPX COOLING TECHNOLOGIES, INC.

7401 WEST 129 STREET  
OVERLAND PARK, KS 66213 USA  
913 664 7400 | spxcooling@spx.com  
spxcooling.com

M SERIES-TS-17B | ISSUED 02/2017  
COPYRIGHT © 2017 SPX CORPORATION

In the interest of technological progress, all products are subject to design and/or material change without notice.

Inpro/Seal® is a registered trademark of Inpro/Seal LLC  
Amarillo® is a registered trademark of Amarillo Gear Company

